

# Urban Railway Transport and DEMU Trains

An Introduction By

U Win Oo, P.E. (No. 0091)

General Manager (Mech.) (Retd.) Myanma Railways

Ex. Co-Project Manager (Yangon Circular Railway Improvement Project-Construction  
Management Consultation)

Rolling Stock Engineer (Yangon-Mandalay Railway Improvement Project Phase 2-  
Construction Management Consultation)

Oriental Consultant Global Co. Ltd.

# URBAN Railway Transport and DEMU Trains

- (1) INTRODUCTION TO RAILWAYS
- (2) BASIC URBAN RAILWAYS
- (3) DEMU URBAN TRAINS



# (1) INTRODUCTION TO RAILWAYS

# Rail/ Track/ Railway

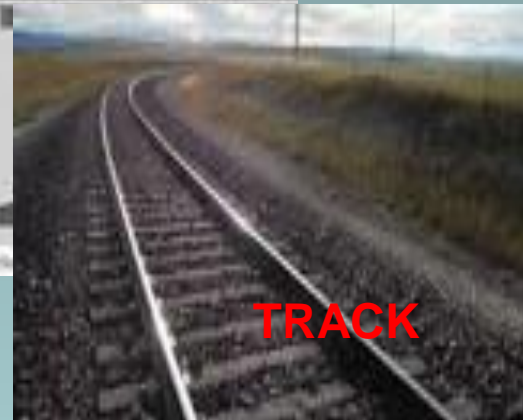

**Rail** → Steel bars for the wheel to run on.

**Track** → Track panel + Track bed

**Railway** → The entire path on which the train runs.



# Railway Gauges

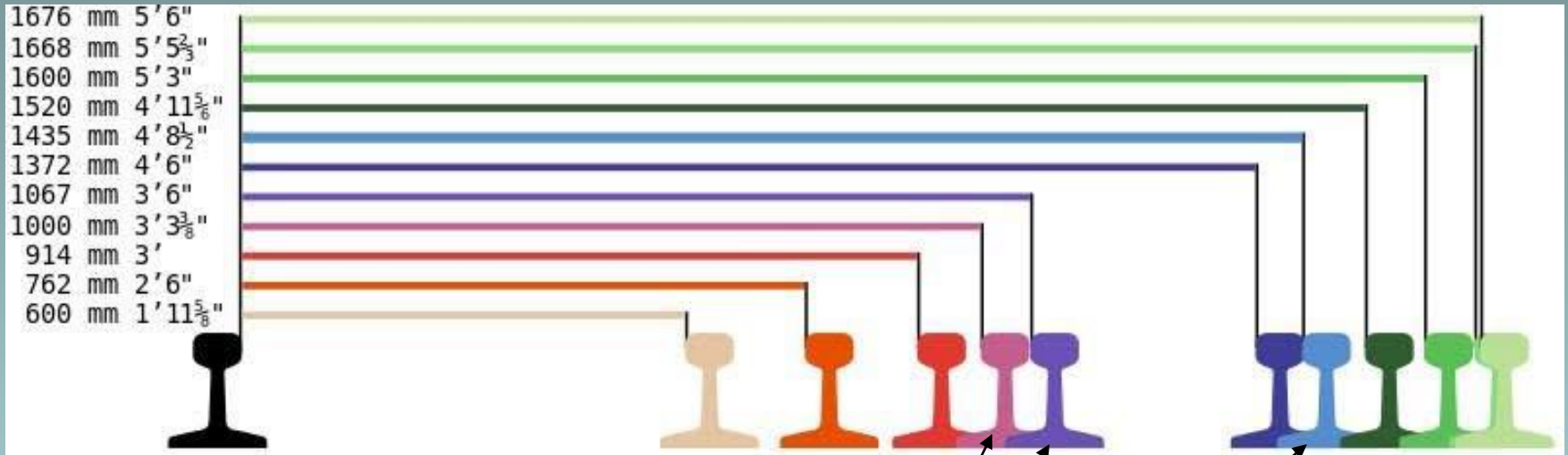

Meter Gauge (Myanmar + ASEAN \_Inland

Cape Gauge (Japan, Indo, Phi, S\_Africa)

Standard Gauge, (Europe, Jp, China)

Russian Gauge (Russia)

Broad Gauge (India)

# Rolling Stock

Vehicle which can be rolled and moved on the railway.



# Type of Trains



1. Passenger Train
  - (a) Locomotive hauled Passenger Cars
  - (b) Diesel Multiple Unit (DMU/RBE)
  - (c) Diesel Electric Multiple Unit (DEMU)
  - (d) Electric Multiple Unit (EMU)
  - (e) Electric Trams
2. Goods Train
  - (a) Locomotive hauled Freight Wagons

# Train Resistance

What difference between  
Roadway and Railways ?



## Train

13 N/ton

at slow speed

(1N=0.22lb,0.1 kgf)

## Road Vehicle

Cart on Virgin Soil 1300-1750 N/ton

Car on bad road 450-650 N/ton

Car on good road 90 N/ton

Ind.Vehicle on road 175 N/ton

# Track Irregularity

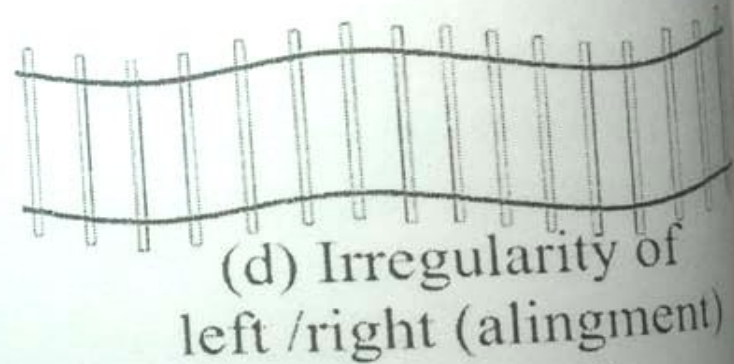
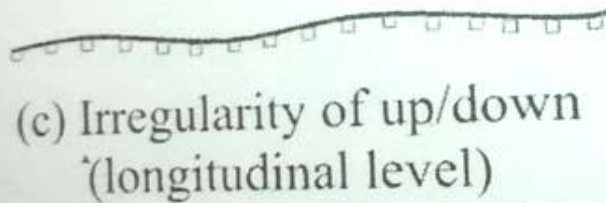
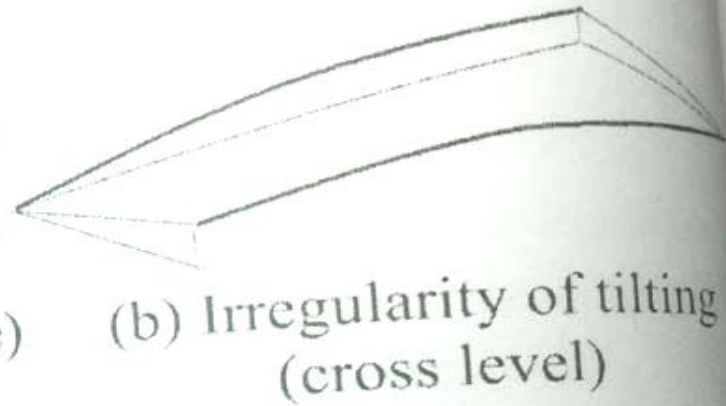
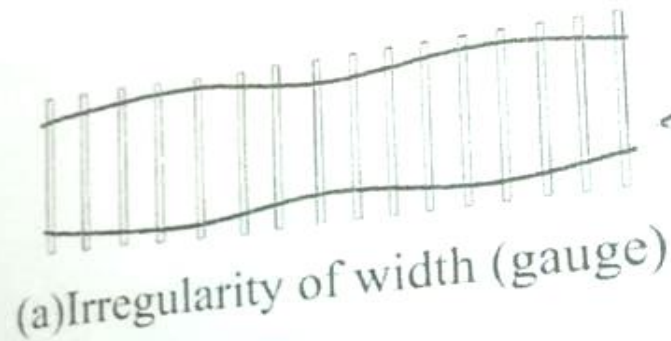

Figure 2-1 Track's inconsistency

# Rolling Stock Vibration

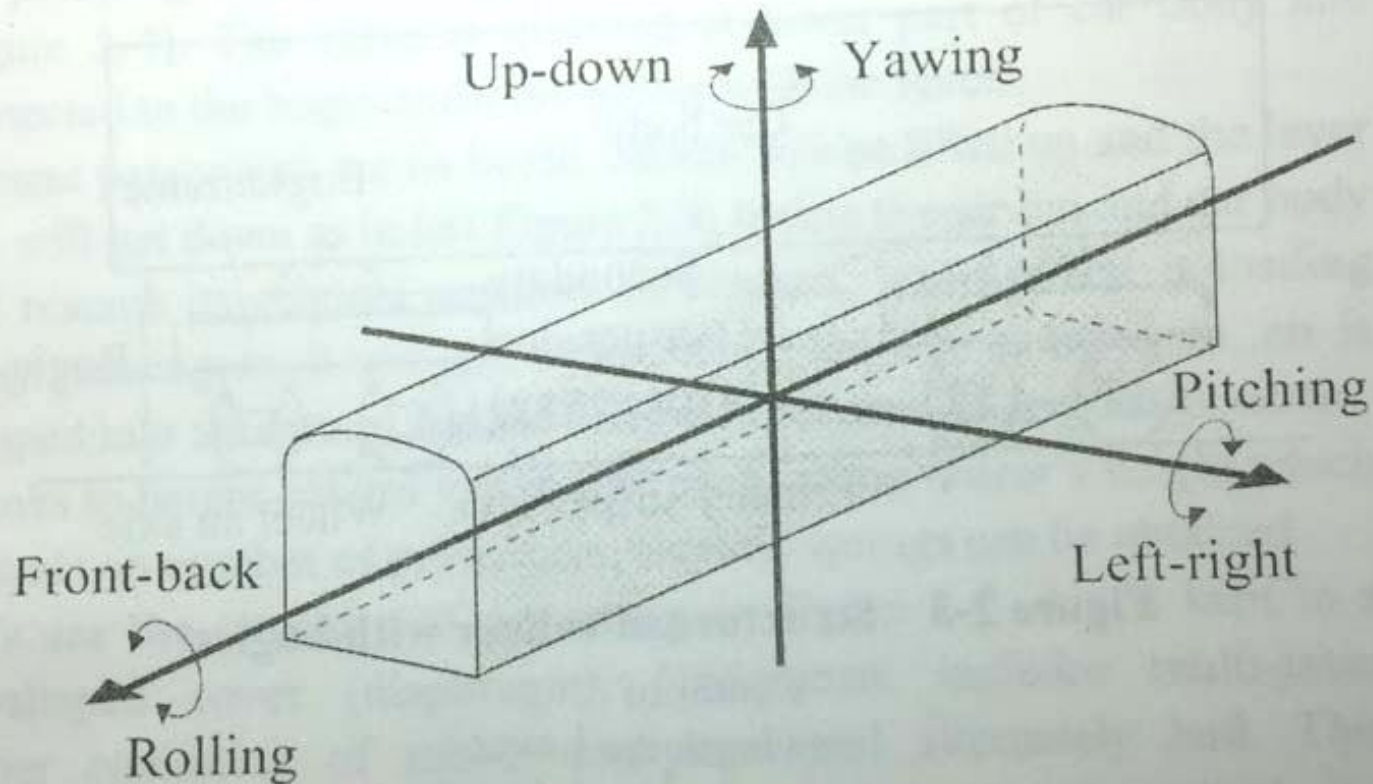

Figure 2-2 3 axis of rolling stock and vibration around 3 axes

# Rolling Stock Suspension

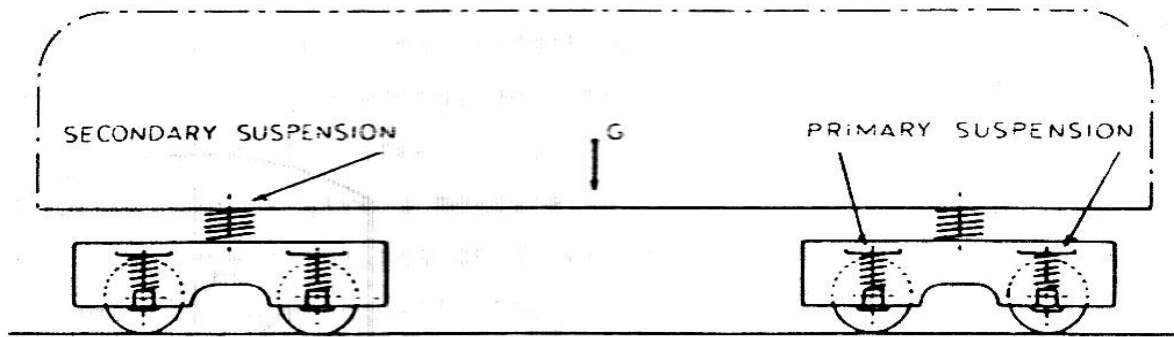
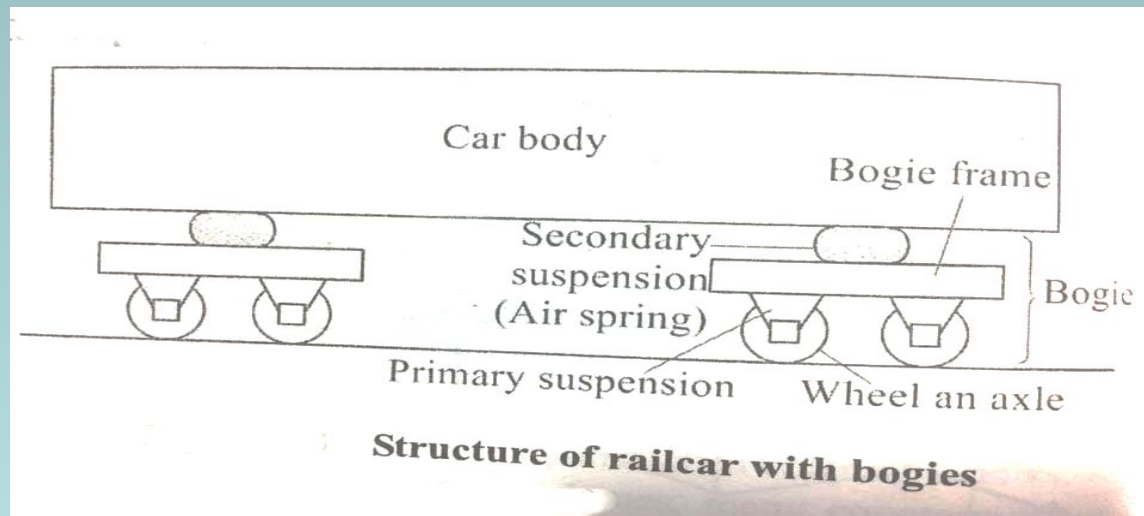

Fig. 392. Suspension of a typical railway vehicle.





## (2) BASIC URBAN RAILWAYS



# Problems in Development of Urban Railways

- Raising the Fund for railway development is difficult. How can we repay the loan?
- What should be done to build a system which is low in cost, high in performance and easy to maintain?
- What policy is required to activate urban railways?
- What should we do to complete the railway construction work without delay?
- How can we have a sustainable management?
- What should be done to increase users of urban railways?
- What is the secret of successfully promoting railway related business?

## Large cities

Jakarta

- electrified commuter transportation (Jakarta MRT).
- Subway opened in 2019.

Manila

- Urban Railway 3 lines.
- extension in progress.

Bangkok

- Sky train opened in 1999.
- opened subway in 2004.

Hochimanh City

- opened subway in 2024.

South korea/China

- Rapid development of Urban Railways in large cities.
- building environmentally friendly cities.



# Basic Concepts for successful urban Railways

## City Structure

(1) highly integrated design - (old cities)



Tokyo



London

Amsterdam



Amsterdam  
1 kilometer  
Numbers refer to tram lines

## (2) dispersed design - (new/wide) cities)



Los Angeles

Nay Pyi Taw

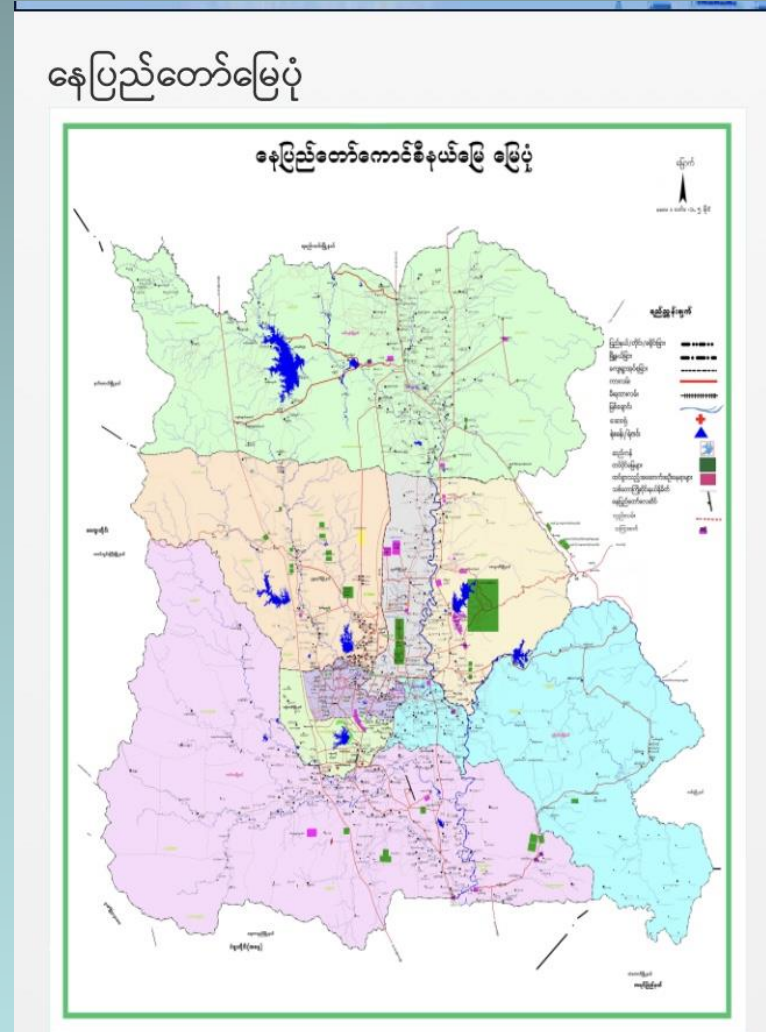

## Basic Concepts for successful urban Railways (continue)

### City Scale

- effective in cities with a population of at least several millions.

### Growth of Personal means of Transportation

- Attracting people

providing faster, more comfortable and convenient service.

### Urbanization and long term Planning strategies

- Money and time

plan for urban railway network should be established slightly ahead of urbanization.

## Urban Security

- to be used safely by people of all classes.
- without security
  - dangerous public transport system
  - using by the poor

## Social, Economic and political stability

- continuous management is required after starting

## Railway Management Mind

- To attract people to use Stations as public area rather than as transport mode
- Excellent management to attract citizens as customers by speed, punctuality, cleanliness, safety, security and comfort.
- Private participation is highly valued.

# CUSTOMER CONVENIENCE

- People who determined to travel by rail usually consider two important factors;
- **walking distance** that is route transferring from railway station to bus or other mode or home;
  - **traveling time** when compared to an alternative mode such as bus.

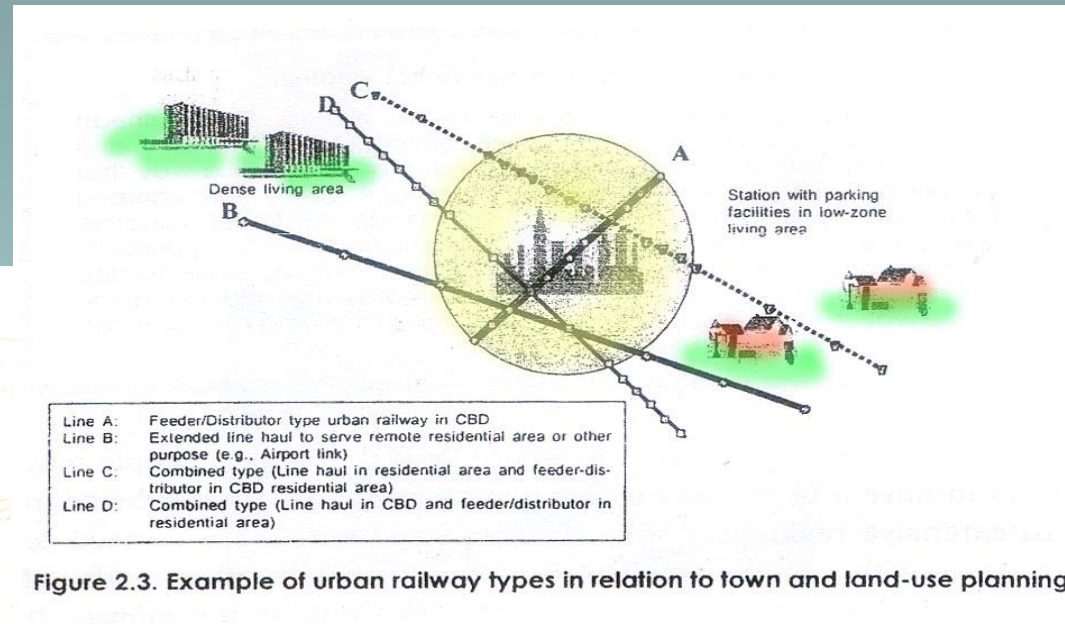
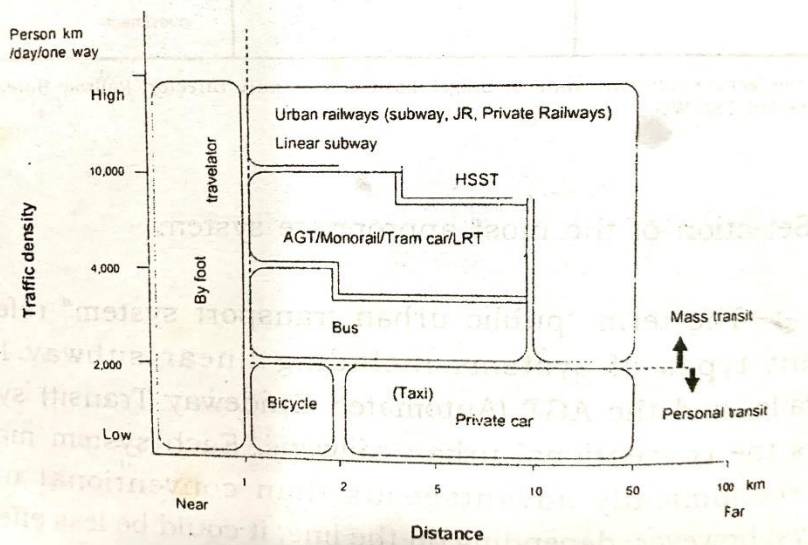

Figure 2.3. Example of urban railway types in relation to town and land-use planning

# Before YCR Project, condition of urban railway in Yangon



Kyi-myin-daing stn (West Yangon)



Inside RBE



Circular Railway



Insein Rolling Stock Depot

# FUTURE TRENDS

## ◆ Urban Railway for Greater Yangon

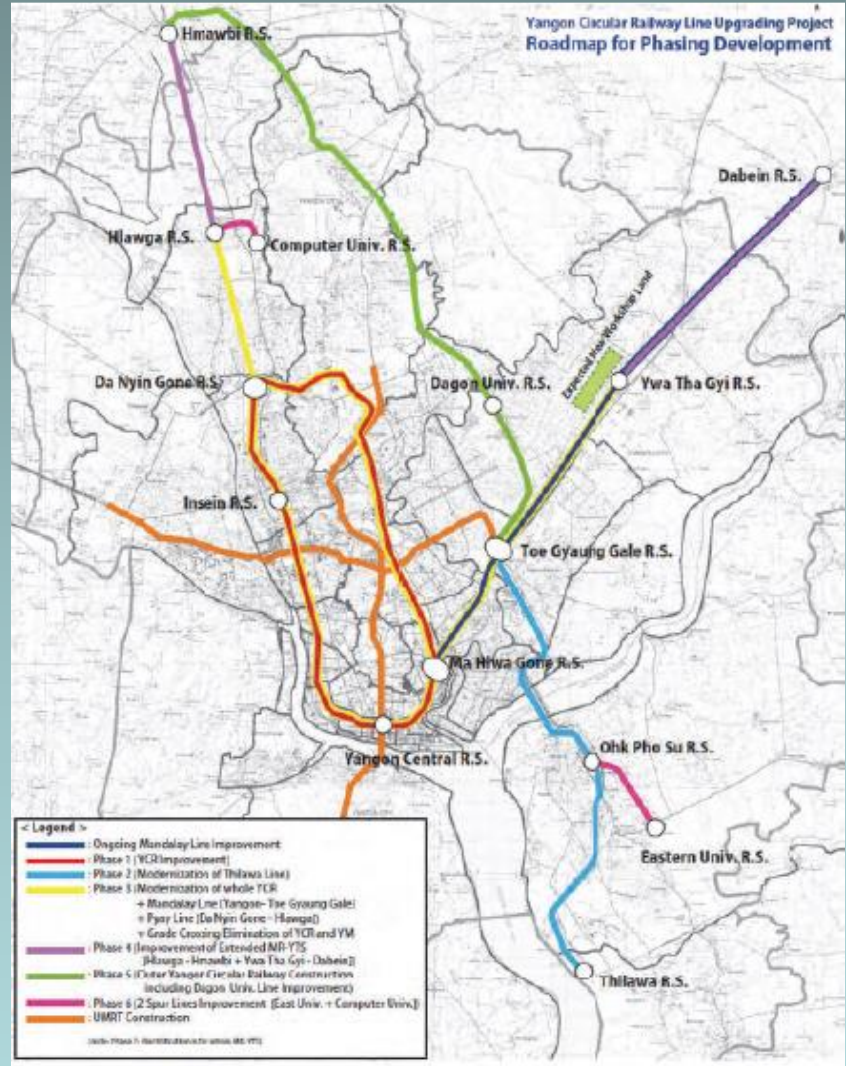
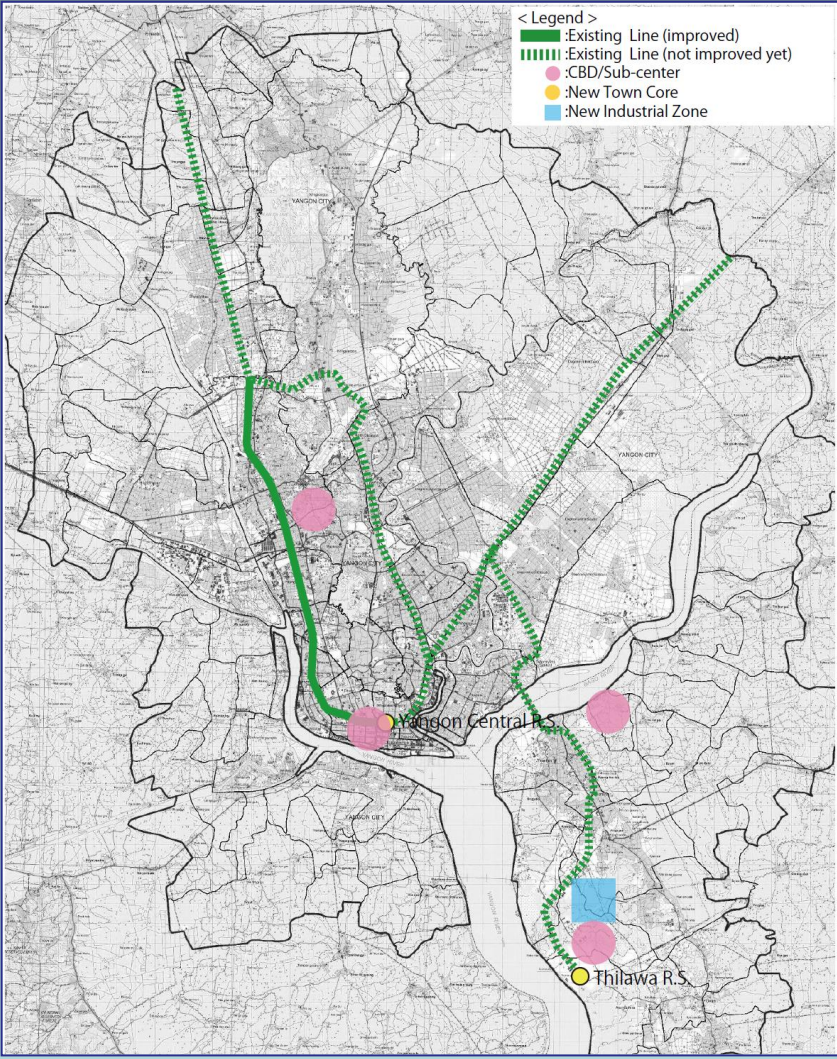

# Project Formation Phases

- The initial improvement work of the whole YCR (Phase 1), which will be carried out using ODA loan for rolling stocks and signalling systems and MR's own budget for the civil works, will complete by 2020.
- Phase 2 Thilawa line will be improved in order to support new social and economic activities on the eastern bank of the Bago River, namely Thilawa area.
- Consequently, radial lines, namely, Pyay line will be improved in Phases 3 and 4.
- The Outer Ring Rail line will be constructed during the Phase 5.
- Spur lines of shorter distance will be improved in Phase 6.
- All projects from Phase1 through Phase 6 shall be carried out by the year

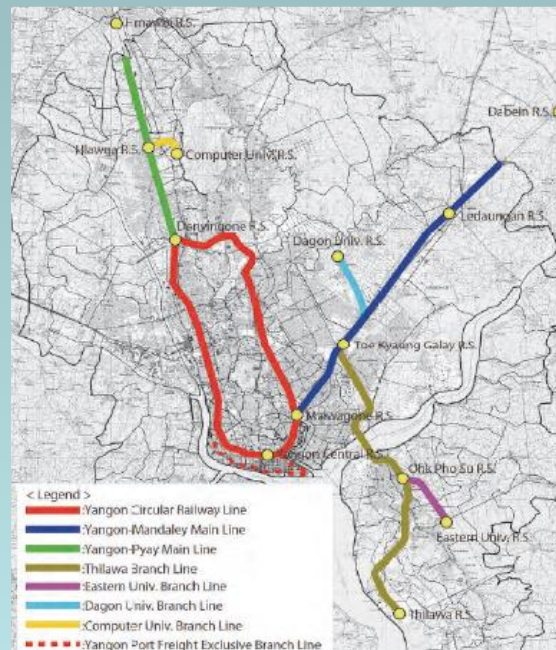

# Technology of the YCR Project

- (1) Construction gauge and loading gauge
- (2) Safety System Improvement
- (3) New DEMU Procurement
- (4) Drainage system improvement
- (5) Improvement of rail track irregularity
- (6) Station platform improvement
- (7) Safety Operation
- (8) **Electrification**

## **(3) DEMU TRAINS**

# Rolling Stock for YCR Project

- Why DEMU ?
- Existing RBEs (DMUs) using in YCR
- DEMU is easier maintenance
- DEMU is Introducing EMU technology before electrification

# Proposed DEMU for Yangon Circular Railway



- DEMU is the start of electrified railways
- You can get the knowledge and experience about EMU through DEMU
- DEMU is almost equivalent to EMU
- DEMU can be a good preparation for the future Electrified Railways
- DEMU is driven by electric energy which is generated by its own engine and generator

## Prospect of Rolling Stock (Passenger) For Myanmar Railways

	Short Term		Middle Term	Long Term
	(2014~2016)	(2017~2024)	(2025~2034)	(2035~)
<b>RBE</b>	<ul style="list-style-type: none"> <li>• Maintenance &amp; Rehabilitation Support</li> <li>• Import Continuously</li> <li>• Establishment of Parts Supply Network</li> </ul>	→		
<b>DEMU</b> (Diesel Electric Multiple Unit)	<ul style="list-style-type: none"> <li>• Technical Support &amp; Preparation</li> </ul>	<ul style="list-style-type: none"> <li>• Yangon-Mandalay Project                             <ul style="list-style-type: none"> <li>- Express Type →</li> <li>- Suburban Type →</li> </ul> </li> <li>• Yangon Circular Line Project                             <ul style="list-style-type: none"> <li>- Commuter Type →</li> </ul> </li> <li>• Local Manufacturing by MR Starts</li> </ul>		<ul style="list-style-type: none"> <li>• DEMU Rehabilitation</li> </ul>
<b>EMU</b> (Electric Multiple Unit)			<ul style="list-style-type: none"> <li>• Electrification of Yangon Circular Line                             <ul style="list-style-type: none"> <li>- EMU (Commuter Type) →</li> </ul> </li> <li>• Electrification of Major Lines (Yangon-Mandalay, etc.)                             <ul style="list-style-type: none"> <li>- EMU (Express Type) →</li> </ul> </li> <li>• Construction of Yangon Urban Railway (Underground, etc.)</li> </ul>	<ul style="list-style-type: none"> <li>• Construction of High Speed Rail - High Speed EMU (Shinkansen)</li> </ul>

# Specifications



Start commercial Operation in YCR line on 30<sup>th</sup> November 2024

# Basic Design Feature of YCR DEMU

- Track Gauge; 1000 mm
- Axle Load; 12.5 Ton
- The Height of Fixed Structure 3,820 mm
- The Height of Rolling Stock gauge 3,505 mm

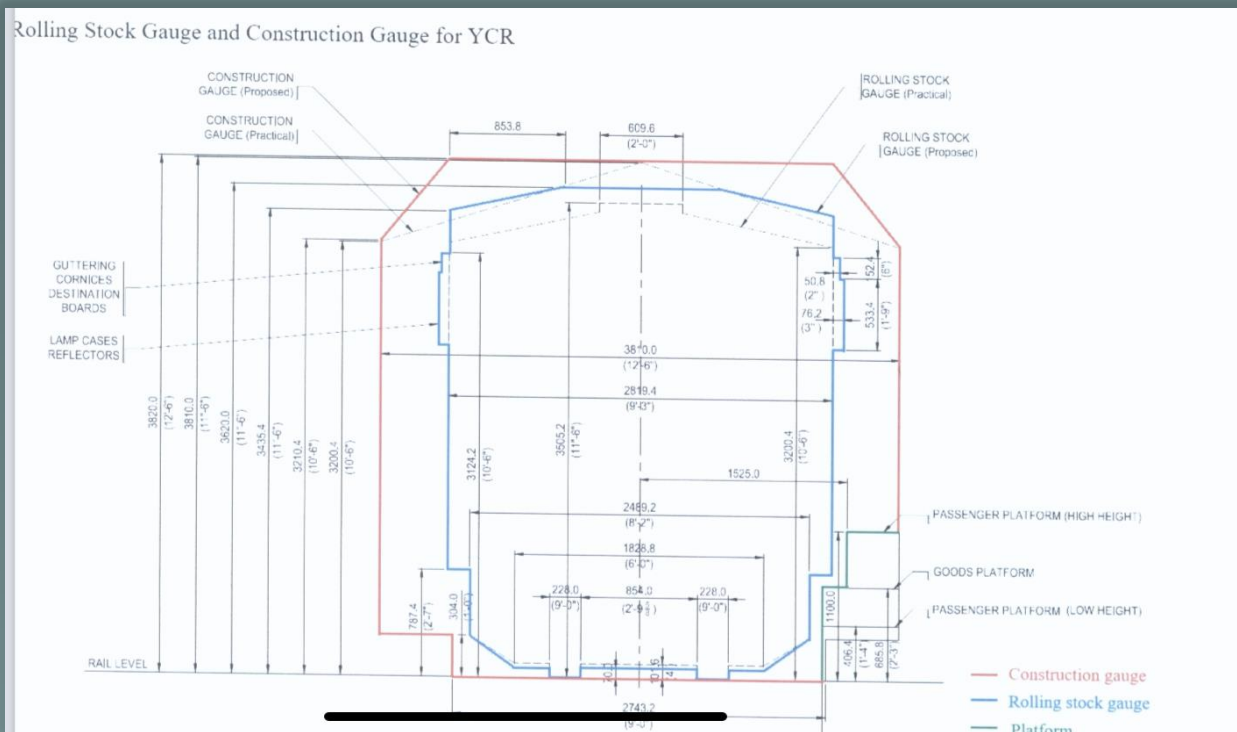

# Performance

- Max. Design Speed; 110 (km/h)
- Max. Service Speed; 60 (km/h)
- Max. Acceleration; 2.0 (km/h/s)
- Max. Deceleration; 3.5 (km/h/s)

# YCR DEMU configuration

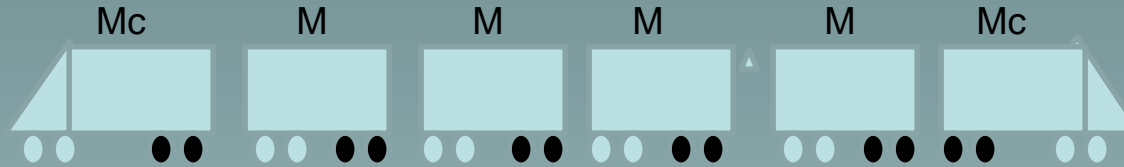

Mc; Traction motor Car with Driving Cab

M; Traction motor Car



# Basic Design Elements of YCR DEMU

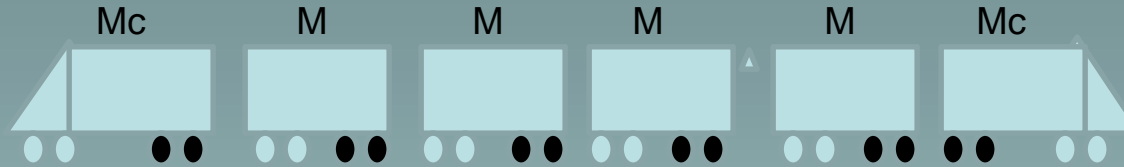

## Main Dimensions

1. Carbody length: 19,100 mm
2. Carbody width: 2,800 mm
3. Roof Height of carbody: 3,595 mm
4. Floor Height: 1,180 mm
5. Distance between Coupler: 20,000 mm
6. Train set length: 120,000 mm
7. Bogie wheel Base: 1,200 mm
8. Wheel Diameter: 860 / 780 mm

# Seat Arrangement

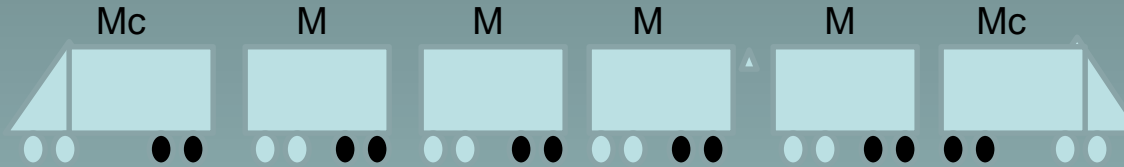

Long –seat type of longitudinal direction which is widely used in major mass transit system in the world  
Wider space for standing passenger

<b>Train Capacity</b>	<b>Mc</b>	<b>M1</b>	<b>M2</b>	<b>TOTAL</b>
Seated	46	58	58	<b>324</b>
<b>Train Capacity</b>	<b>Mc</b>	<b>M1</b>	<b>M2</b>	<b>TOTAL</b>
PRM	1	-	-	<b>2</b>
Standing (3,3 p/m <sup>2</sup> )	88	90	90	<b>536</b>
<b>Total AW2: Seated + Standing (3,3 p/m<sup>2</sup>)</b>	<b>134</b>	<b>148</b>	<b>148</b>	<b>860</b>

**Train passenger capacity**

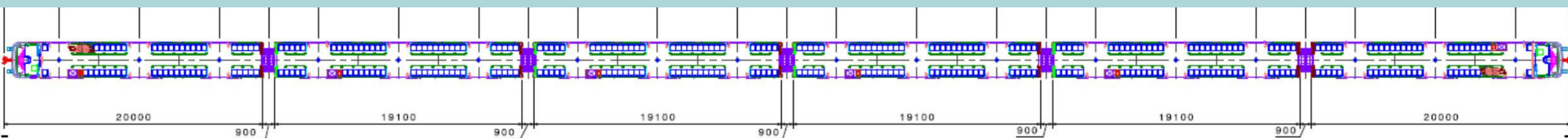

## Side Door Arrangement

The side door arrangement of YCR DEMU is a three-door type at each side of railcar. Each door clear open 1300 (mm) in order to reduce the boarding and alighting time.



Carbody Material is Aluminium

## Electrical System

The electrical system of YCR DEMU consists of diesel engine, generator, converter, inverter, and auxiliary power supply system and Traction Motors.

### DEMU Electrical supply system block diagram

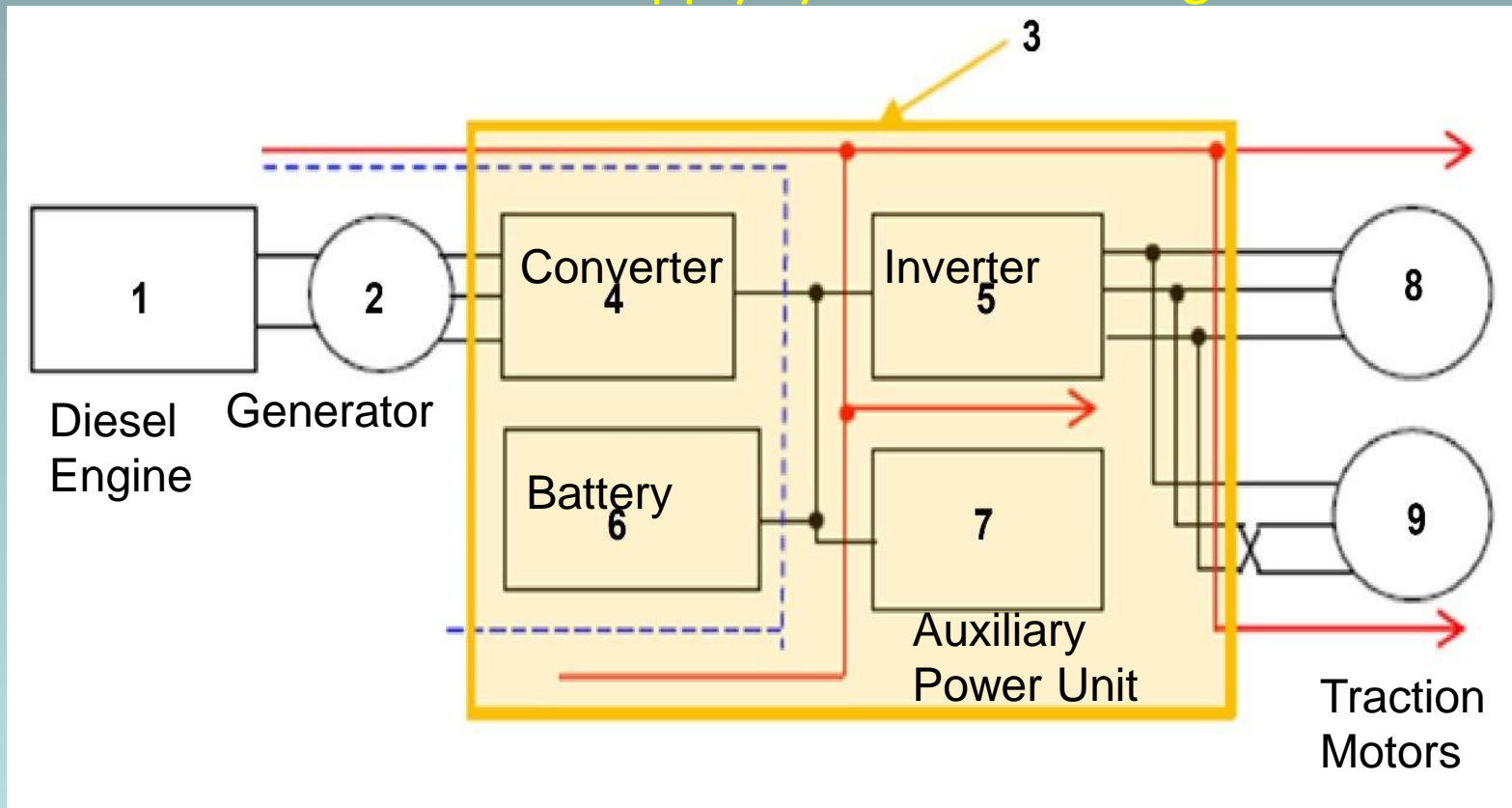

## Bogie

The each car equips one powered non-articulated bogie with two traction motors and one un-powered (trailer) non-articulated bogie. The type of bogie is the bolsterless and the secondary suspension is the air suspension.

## Brake System

The pressurized air for air brake system comes from the air compressor driven by the motor. The command system for the air brake system is the electrical command system. The braking devices for the mechanical brake system are the axle-mounted disc brakes for both power bogie and trailer bogie.



## Safety Device

Automatic Train Protection (ATP) according to the signalling improvement plan for the YCR Line Upgrading Project. The on-board antenna is located on the underfloor and the ATP on-board devices including the alarming device and the confirmation button are located on the cab room.

## Air Conditioning System

One unit with the air compressor cooling and ventilating system mounted on the roof top



# Condition Monitoring System and Passenger Information Device (System)

The condition monitoring system which monitors the condition of the main components such as the propulsion system, the brake system, the side door system, the air conditioning system. Additionally the destination indicator and the next station indicator of LED for passengers installed.



IMI in Driver Desk



Outside Display



Route Display

## Coupling

Tight lock type automatic couplers are fitted on both front end of the train, at driver's cab. The height of the coupling device is 880 mm. Semi-permanent couplers are fitted for coupling the intermediate cars.



Semi-permanent Coupler

Automatic Coupler



# Testing

	Type Test	Routine Test	Service Trial
1. Factory Test (detail Eqpt.)	o	o	
2. Factory Acceptance Test (First train, prototype)		o	
3. Type test of first train at test center	o		
4. Type test of first train in MM	o		
5. Factory Acceptance Test as routine test of all train sets (Function Test)		o	
6. Acceptance Test/Integration Test all train in MM		o	
7. Service Trial (YCR)			o

# Standard Applied

- Carbody Structure EN 12663
- Crashworthiness EN 15227 C-II
- Rules for Installation of cabling EN 50343
- Testing of Rolling Stock EN 50215
- Rolling stock protective provision Relating to Electrical Harzard EN 50153
- Interior and Exterior Noise Test ISO 3381-2005  
ISO 3095-2013
- Roughness of Rail ISO 15610:2019

Thank You

Questions and Answers